

Big Dutchman®

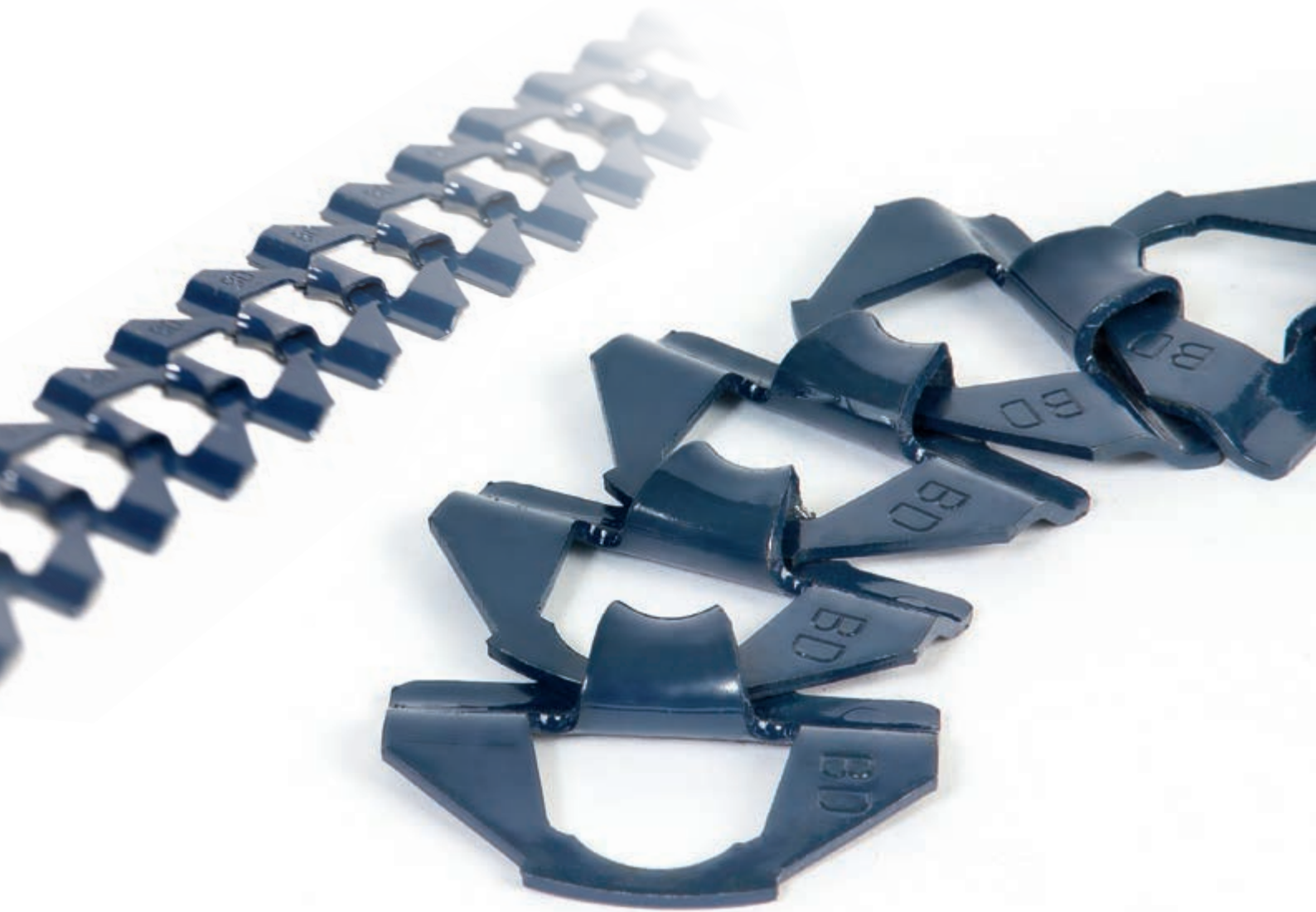

Automatic chain feeding

for modern poultry production

Automatic chain feeder – a reliable and successful system u

Big Dutchman introduced the world's first automatic chain feeding system as early as 1938. Daily hand-feeding of the flock was very time-consuming, triggering the idea of an automatic feeder system: A new era dawned for the poultry industry. Thanks to its robust and simple principle, the chain feeding system has proved itself a million times over. The basic concept – feed hopper, drive unit, corner, trough and the CHAMPION feed chain – has remained unchanged. The entire system, however, is

continuously being improved and adapted to today's requirements for modern poultry production. The Big Dutchman feed chain CHAMPION can be used for any type of production, including layer breeders kept in cages, pullets from their first day of life and laying hens. The chain also feeds broiler breeders reared on the floor and is furthermore a great option in alternative egg production.



First automatic chain feeding system in 1938 in the USA

Cage management



Layer breeders



Pullet rearing



Layers

Floor management



Broiler breeders



Pullet rearing



Layers

The world's leading feeding system

We have sold approximately 150,000 km of our feed chain up to today. A chain of this length would literally be long enough to loop it around our planet nearly four times. Increasing sales figures and the fact that the chain is delivered to destinations worldwide prove its high quality and exceptional reliability. Our sales team says: »We would have sold so much more chain if it did not have such an impossibly long life! 30 years are really not uncommon.« Our customers appreciate

this quality, and we therefore see no reason to change the chain's material and design.



Used the world over for more than 75 years!



»Only the original guarantees unsurpassed quality – recognise it easily thanks to the engraving!«



Advantages of the Big Dutchman chain feeding system

- ✓ different conveying speeds of 12, 18 or 36 m/min, depending on the requirements;
- ✓ high conveying capacity of up to 1.5 t/h reduces the number of feedings;
- ✓ any type of feed can be used, e.g. mash, pellets and crumbles;
- ✓ the feed is distributed uniformly and reliably, i.e. all birds receive the same amount and quality of feed, with minimum feed losses;
- ✓ controlled or ad libitum feeding are both possible, depending on the demand;
- ✓ the feed level in the trough can be adjusted with the feed level slide;
- ✓ the shape of the trough guarantees sufficient space for all birds: birds can feed from both sides without stress;
- ✓ the system can be suspended or installed on legs for floor management;
- ✓ cost-efficient feeding system;
- ✓ simple, thorough cleaning;
- ✓ low labour and maintenance requirements;
- ✓ robust system, long service life.

Important components



Drive unit

- ✓ chain speed: 12, 18 or 36 m/min;
- ✓ motor output: 0.37 / 0.75 / 1.1 / 1.5 or 2.2 kW, depending on the circuit's length;
- ✓ one- or two-line design;
- ✓ simple height adjustment for the standing version.



90° corner

- ✓ through-hardened guide rail;
- ✓ plastic bearing which needs no lubrication;
- ✓ stable housing with removable cover, also available as galvanized version;
- ✓ high functional reliability, minimum wear and tear, easy to maintain.



Trough with feed chain

- ✓ birds can feed from both sides;
- ✓ minimum feed losses;
- ✓ easy to clean and to service;
- ✓ trough coupler is required for a perfectly straight feed line;
- ✓ suspended or standing version.

General planning instructions

Type of bird	Stocking density birds/m ²	Feeding method	No. of birds/m trough	cm trough side/bird	Feed demand/bird/day in g
Broiler breeders (rearing)	7 - 10	restricted	14 - 17	12 - 14	up to 100
Broiler breeders (production) Ø 3.5 kg	4.5 - 6.5	restricted	12 - 15	12 - 15	130 - 185
Laying hens Ø 2 kg	6 - 8	ad libitum	20 - 25	8 - 10	110 - 130
Pullets Ø 1.5 kg	8 - 10	rationed	20 - 25	8 - 10	20 - 110
Broilers 1.5-1.7 kg	22 - 24	ad libitum	50 - 65	3 - 4	20 - 150
Broilers 1.7-2.5 kg	18 - 20	controlled	30 - 40	5 - 7	20 - 190

The bird numbers shown in the diagram are average values and can vary depending on the breed and climate.

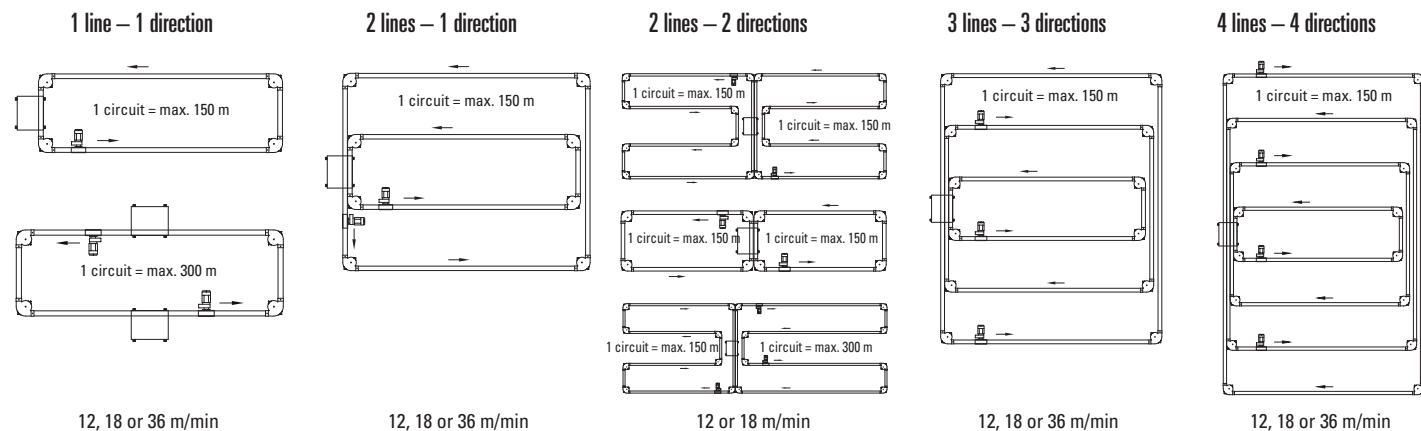

Further configurations for the feed lines are available. Let our experts advise you.

Feed hoppers

Type of hopper		MPF 1 line	MPF 2 lines	MPF 3 lines	Mini 1 line	Mini 2 lines	Mini 3 lines	Mini 4 lines
Feed hopper	litres	110	150	190	50	70	90	110
MPF extension	litres	258	305	357	-	-	-	-
Mini extension	litres	-	-	-	240	240	240	240
Weighing container	litres	1250/1850	1250/1850	1250/1850	1250/1850	1250/1850	1250/1850	1250/1850
Legs		●	●	●	○	○	○	○

100 litres amount to approx. 65 kg of feed.

● Standard equipment

○ Special equipment

Drive units*¹

Designation		MPF 12 m/min		MPF 18 m/min	MPF 36 m/min* ²		
Motor output in kW	3 Ph, 50 Hz	0.37	0.75	1.1	1.1	1.5	2.2
Max. chain length in m* ³	1 line	180	300	300	180	200	300
Max. chain length in m* ³	2 lines		2x125	2x125			

*¹ A circuit should take no longer than 3 to 5 minutes for controlled feeding.

*² For 36 m/min drives, we recommend a time control with seconds program.

*³ The indicated chain length is valid including four 90° corners. For each additional corner, reduce the maximum chain length by 12.50 m.

For single-phase motors and for chain feeding in the litter area, reduce the maximum chain length by 30 percent.



Big Dutchman

Germany:
Big Dutchman International GmbH
Postfach 1163 · 49360 Vechta
Tel. +49(0)4447 801-0 · Fax -237
big@bigdutchman.de
www.bigdutchman.de

USA: Big Dutchman, Inc.

Tel. +1 616 392 5981 · bigd@bigdutchmanusa.com
www.bigdutchmanusa.com

Brazil: Big Dutchman (Brasil) Ltda.

Tel. +55 16 2108 5310 · bdbbr@bigdutchman.com.br
www.bigdutchman.com.br

Russia: 000 "Big Dutchman"

Tel. +7 495 229 5161 · big@bigdutchman.ru · www.bigdutchman.ru

Asia/Pacific: BD Agriculture (Malaysia) Sdn. Bhd.

Tel. +60 3 3361 5555 · bdasia@bigdutchman.com · www.bigdutchman.com

China: Big Dutchman (Tianjin) Livestock Equipment Co., Ltd.

Tel. +86 10 6476 1888 · bdcnsales@bigdutchman.com
www.bigdutchman.org.cn