



Big Dutchman®



Manure Pit Systems

for organic, barn and free-range egg production

Manure pit systems – animal-friendly and easy to monitor

Whichever type of alternative layer management you select: we have the right product for you!

Good housing equipment must consist of carefully considered and coordinated

individual components: feed and water supply, nests, perches, manure removal and climate control systems. This is a central prerequisite for healthy hens and a high laying performance.

Our modern manure pit systems are very animal-friendly and easy to monitor, and they can be fitted into the majority of barns.

Colony 2+ group laying nest – well accepted by the hens, excellent egg quality

The correct laying nest plays an important role when looking for economic success. Reducing the number of misplaced, dirty and cracked eggs is crucial for this goal. Depending on the house layout, Big Dutchman nests are available with one or two tiers and as wall or double nests.

Colony 2+ has the following advantages:

- ✓ short rolling-off distances for the eggs
→ excellent egg quality
→ smooth transfer to the egg belt
- ✓ clever nest design with folding roof
→ easy nest inspection
→ easy cleaning
→ no hidden corners for mites
- ✓ divided, tilting nest floor
→ eggs left in the nest automatically roll off towards the egg belt when the nest closes
- ✓ the tilting floor closes the nest after the laying period
→ dirt of the day drops off the nest insert
→ the nest remains clean
→ low percentage of dirty eggs
- ✓ nest depth of 53 cm
→ 153 hens per tier in wall nests
→ 305 hens per tier in double nests



Colony 2+ group laying nest as single-tier wall nest



Colony 2+ group laying nest as single-tier wall nest



The tilting floor closes the nest after the laying period

Nest cross sections and dimensions

Single-tier wall nest

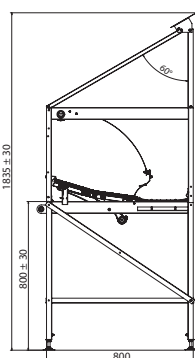

Single-tier double nest

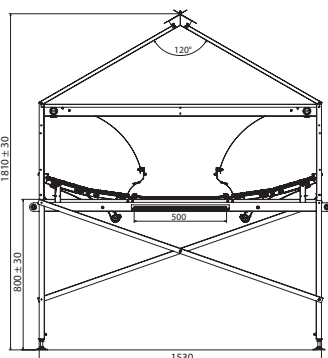

Two-tier wall nest

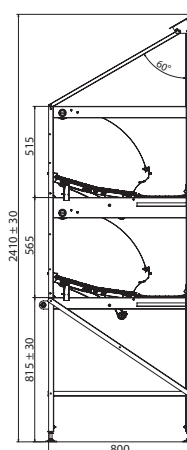

Two-tier double nest

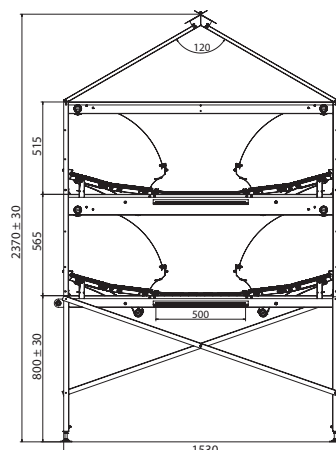

Manure pit

To improve hygiene inside the house, part of the house should be used as a manure pit and equipped with slats. With both drinker and feed lines located above the manure pit, this is also the area where the majority of the droppings is deposited. All manure is stored in the manure pit for the entire laying phase. After the batch, the manure pit is dismantled so the manure can be removed from the house.



Manure pits store excrements for the entire laying phase



Longitudinal supports for wide manure pits

Plastic slats

The plastic flooring designed by Big Dutchman is ideally suited for laying hens. Its advantages include:

- ✓ exceptionally high hygiene due to the smooth surface;
- ✓ secure foothold for the hens;
- ✓ small surface area for good manure penetration, the slats stay clean for the entire batch;
- ✓ no contact surface between the slats → for easy and thorough cleaning → no hotbeds for mites and other vermin;
- ✓ no sharp edges or corners, i.e. reduced risk of injury;



Plastic slat covering the manure pit

- ✓ easy-to-install flooring that can be dismantled quickly after the batch;

- ✓ high durability;
- ✓ long service life.

Metal slats

In addition to the plastic slats, Big Dutchman can also offer a metal slat. This metal slat is mainly used in fully-slatted houses that are equipped with a manure removal system, e.g. a manure scraper below the slats. Metal slats are heavier than plastic slats but easy to clean, even when still installed. Dismantling the manure pit is thus not necessarily required when using metal slats.



Fully-slatted house with wire flooring above the manure pit

A-frame perches made of metal – raised resting areas for increased comfort

Modern manure pit barns are equipped with A-frames to be able to offer the required amount of perches. Big Dutchman can provide the A-frames 3000 and 5800.

They are made of metal and the ideal choice both for manure pit and fully-slatted houses. Hens naturally like to perch in a high place at night. Our simple

A-frames provide a raised resting area and can also easily be combined with feed and drinker lines.

The A-frame 3000 is designed to run the length of the manure pit. It has three perches and can be installed with or without feed line, as required. Due to its low weight, the A-frame can be winched up to the ceiling during cleaning.



A-frame 3000 with three perches and one feed line

The A-frame 5800 can be equipped with up to eight perches, two feed lines and one drinker line.

This system provides full flexibility to meet your specific stocking requirements.



A-frame 5800 with six perches, two feed lines and one drinker line

Feed supply

Feed is supplied by the well-proven Big Dutchman chain feeding system.

Its advantages are well-known:

- ✓ the Champion feed chain distributes feed rapidly and evenly throughout the entire house;
- ✓ the maintenance-free 90° corner ensures a trouble-free feed circuit;
- ✓ additional perching is available thanks to a tube above the trough that prevents soiling of the feed below;
- ✓ the rugged plastic legs have a long service life, even when placed in the litter;
- ✓ the combination of suspended and standing troughs makes it possible to winch the system up towards the ceiling for cleaning purposes;
- ✓ durable and solid technology that has been proving its worth for many decades.



Fully-slatted house with suspended/standing feeding system



90° corner with Champion feed chain



Feed trough with perch



Plastic legs, also available with 4° or 8° inclination, depending on the manure pit

Water supply

In order to provide the layers with clean and hygienic drinking water, we recommend using nipple drinkers. Nipple drinker lines can be suspended from the ceiling or stand on legs. Large or small drip cups beneath the nipples ensure that the manure remains dry.



Top nipple orange with large drip cup



Stainless steel Top nipple with small drip cup



Nipple drinkers and chain feeding system, installed in both suspended and standing position

Examples for different house layouts

Traditional manure pit house

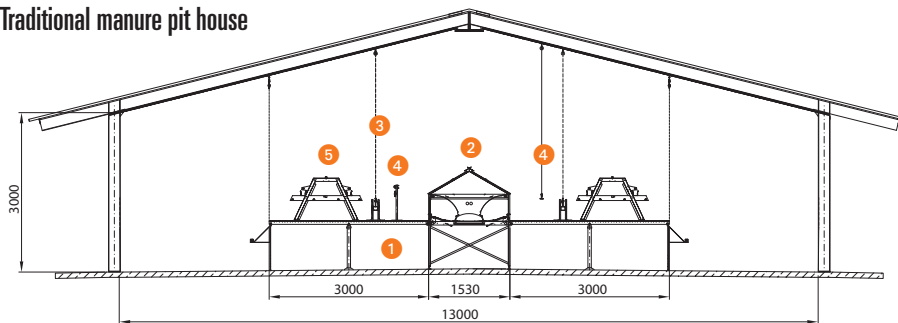

Key

- 1 Manure pit with plastic slats
- 2 Colony 2+ group laying nest as double or wall nest
- 3 Trough with feed chain, standing and/or suspended
- 4 Nipple drinkers, standing and/or suspended
- 5 A-frame 5800 with feed and/or drinker line and up to 8 perches
- 6 A-frame 3000 liftable with feed line and 3 perches
- 7 Winter garden

Fully-slatted house with winter garden as litter area

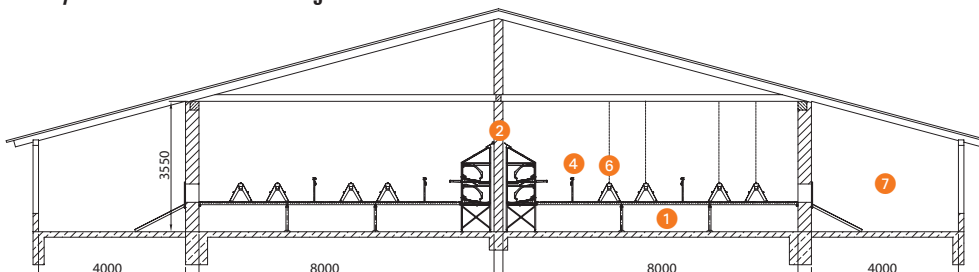

Manure belt system NATURA Sunrise

Big Dutchman can now offer its customers the new manure belt system NATURA Sunrise, which is easy to monitor and to manage.

In contrast to manure pit systems, NATURA Sunrise has manure belts that are installed below the drinker and feed lines. These belts collect the manure and

remove it from the house at regular intervals, thus reducing ammonia emissions and creating a good climate inside the barn.



NATURA Sunrise – more system surface for higher stocking densities compared to manure pit systems



The connecting aisle between nest and feed and drinker lines increases nest acceptance

Cross sections of NATURA Sunrise

NATURA Sunrise – basic version

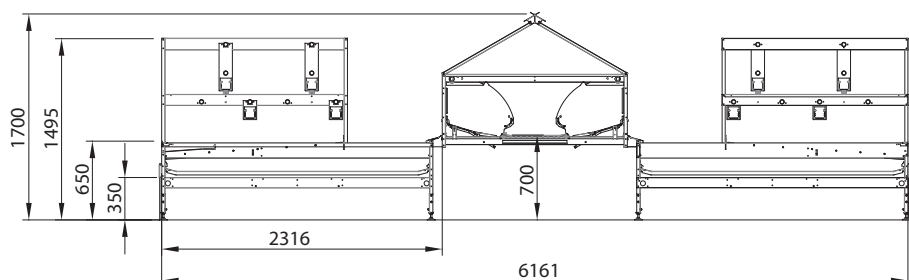

NATURA Sunrise is available in three versions that differ with regard to additional system surface above the nest. NATURA Sunrise 21-18 comes with an additional drinker line directly in front of the nest.

NATURA Sunrise 21-15 – 33 % more system surface

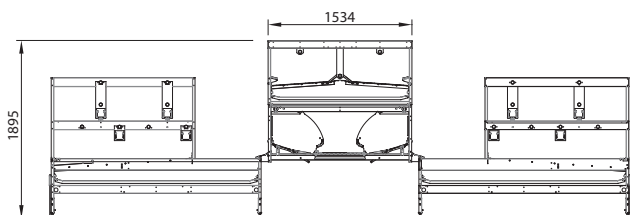

NATURA Sunrise 21-18 – 40 % more system surface

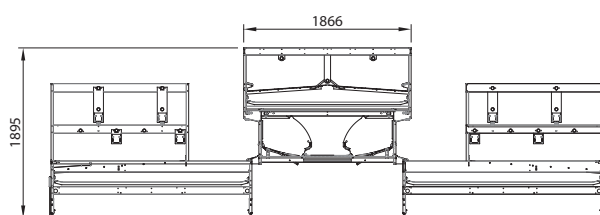

Big Dutchman.

Europe, Middle East & Africa:
Big Dutchman International GmbH
 P.O. Box 1163 · 49360 Vechta, Germany
 Tel. +49(0)4447 801-0 · Fax -237
 big@bigdutchman.de
 www.bigdutchman.de

USA: Big Dutchman, Inc.
 Tel. +1 616 392 5981 · bigd@bigdutchmanusa.com
 www.bigdutchmanusa.com

Brazil: Big Dutchman (Brasil) Ltda.
 Tel. +55 54 2101 5900 · bigdutchmanbrasil@bigdutchman.com.br
 www.bigdutchman.com.br

Russia: 000 "Big Dutchman"
 Tel. +7 495 2295 161 · big@bigdutchman.ru · www.bigdutchman.ru

Asia/Pacific: BD Agriculture (Malaysia) Sdn. Bhd.
 Tel. +60 33 34 83 555 · bdasia@bigdutchman.com · www.bigdutchman.com

China: Big Dutchman (Tianjin) Livestock Equipment Co., Ltd.
 Tel. +86 10 6476 1888 · bdcnsales@bigdutchman.com
 www.bigdutchman.cn